

Multi-Channel Power Amplifiers

CX-A450 & CX-A850

482.6mm / 19"



88mm
/ 3 1/2"
(2U)

Cloud CX-A450 front view

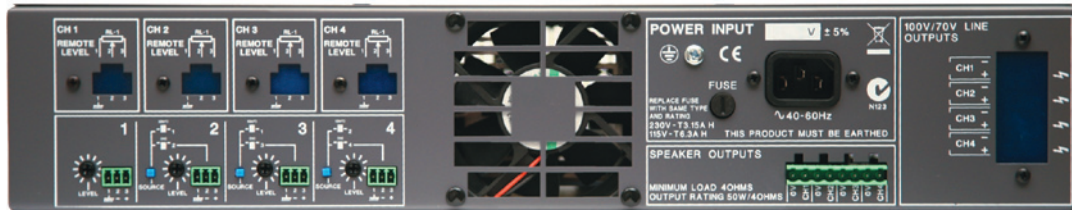

Cloud CX-A450 rear view

482.6mm / 19"



88mm
/ 3 1/2"
(2U)

Cloud CX-A850 front view



Cloud CX-A850 rear view

General Description

The Cloud CX-A450 and CX-A850 are high-quality multi-channel power amplifiers designed for relatively low-power sound reinforcement applications in commercial or industrial premises. They are ideal for situations where the various locations of the building require different programme material and/or levels.

The two models are:

Model	Power
CX-A450	4 x 50 W
CX-A850	8 x 50 W

The amplifiers will deliver their rated power into 4 ohm loads for long periods of time. Safety features of the design include Cloud's Dynamic Clipping Protection circuitry, VI limiting, switch-on delay (5 seconds) and protection against DC offset or thermal overload. Both models are built in a 2U steel enclosure, and use variable-speed forced-air cooling.

Any two channels may be wired in Bridge Mode, allowing power outputs of double the normal rating to be delivered to a load of 8 ohms (minimum).

In addition to the power switch and associated LED, the front panel is fitted with three LEDs for each channel, confirming signal presence, peak level and activation of the protection circuitry. Rear panel controls are provided for individual channel gain trims and input routing to configure the amplifier in various combinations of mono, stereo or multi-channel operation. The inputs are electronically balanced.

The CX-A450 and CX-A850 may also be used with 100 V/70 V-line loudspeaker systems by the addition of standard Cloud accessories. The CXL-4160 is a four channel transformer module which can be internally fitted to the CX-A450, while the CXL-40T is a single channel toroidal transformer module for external mounting. For installation convenience, the CXL-800, a 2U rackmounting assembly which can hold up to eight CXL-40s, is also available. To prevent LF transformer saturation in 100 V/70 V-line systems, a 65 Hz high-pass filter may be enabled for each channel individually, by internal jumper.

Other standard options are Cloud RL-I remote volume control plates, the VCA-5 single-channel VCA card (required for level control by RL-I), and EQ cards to suit various makes and models of loudspeakers. Remote level control or speaker EQ may be fitted to any or all channels.

- General purpose, high quality 4 and 8-channel power amplifiers with superior audio performance
- 4 x 50 W (CX-A450) or 8 x 50 W (CX-A850) into 4 ohms
- Very low inter-channel crosstalk
- Thermal protection
- VI limiting
- DC offset protection
- Dynamic Clipping Protection
- Switch-on delay (for speaker protection during power rail stabilisation)
- Pairs of channels may be operated in Bridge Mode
- Per-channel, front-panel LEDs for signal presence, peak level and protection status
- Balanced line level inputs with gain trim
- Rear panel switches to configure for multichannel, stereo or mono operation
- Optional internal 4-channel 100V/70V transformer module (CX-A450 only)
- Optional externally-mountable 100V/70V transformers (per channel)
- Optional remote volume control (per-channel)
- A range of optional per-channel EQ cards, to match various popular loudspeakers
- 2U 19" rackmounting units
- Variable speed forced-air cooling
- Five year warranty

Block Diagram

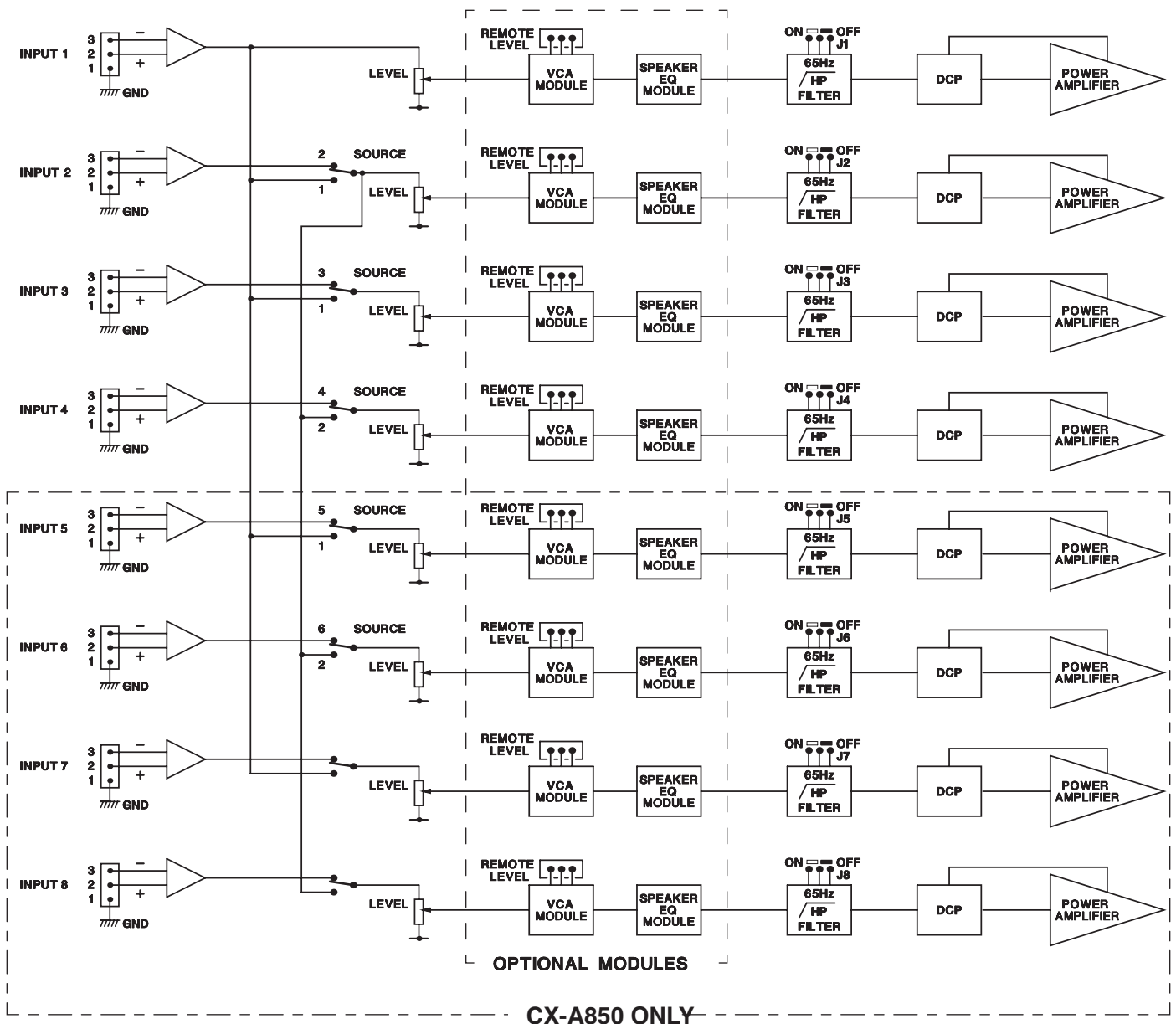

Input Routing

The input routing switches of the CX-A450 and CX-A850 permit various permutations of mono, stereo and multi-channel operation without any external parallel wiring. Some possibilities are shown below:

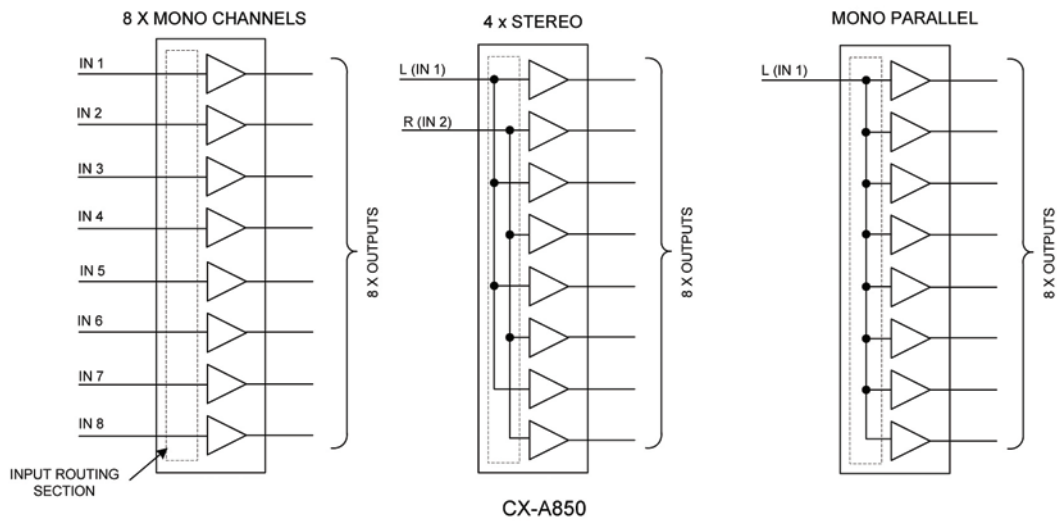
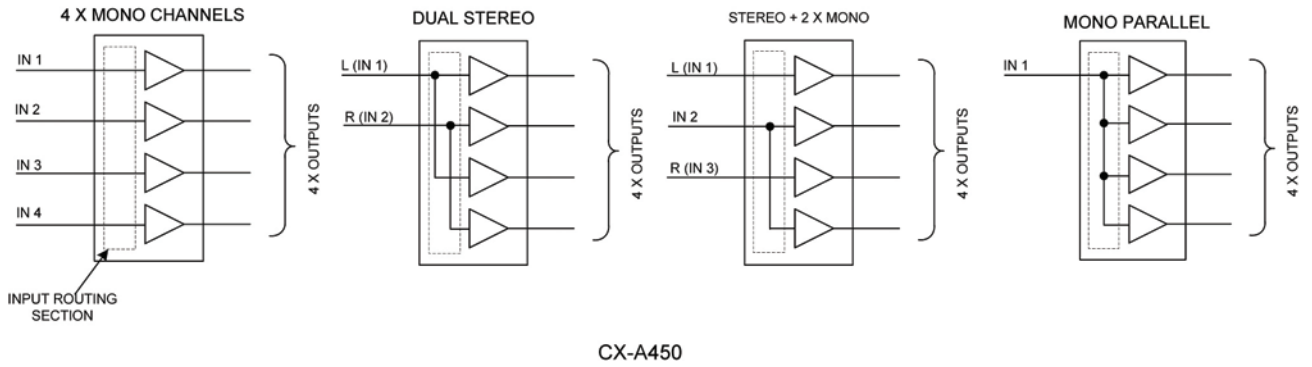

System Example

CX-A450 and CX-A850 amplifiers' exceptional crosstalk performance make them particularly suitable for any application where different audio sources need to be routed to various zones (parts of a building). They are equally suitable in a situation where a common audio source needs to be reproduced at different levels in various zones. The flexibility of the amplifiers' input routing makes it possible to handle a mixture of mono and stereo sources without complex wiring.

In many applications, the power amplifiers will be used in combination with a Cloud Zoner, to permit paging and emergency override. An example is the CX263 zoner, which supports three zones, one of which may be stereo. In the example shown below, where a CX263 is used with a CX-A450, Chs. 1 & 2 are used to drive stereo to Zone 1, while Chs. 3 & 4 are used for the mono signals to Zones 2 and 3 respectively.

Similar mono-stereo arrangements are possible with the Cloud CX163 and Z411 zoners.

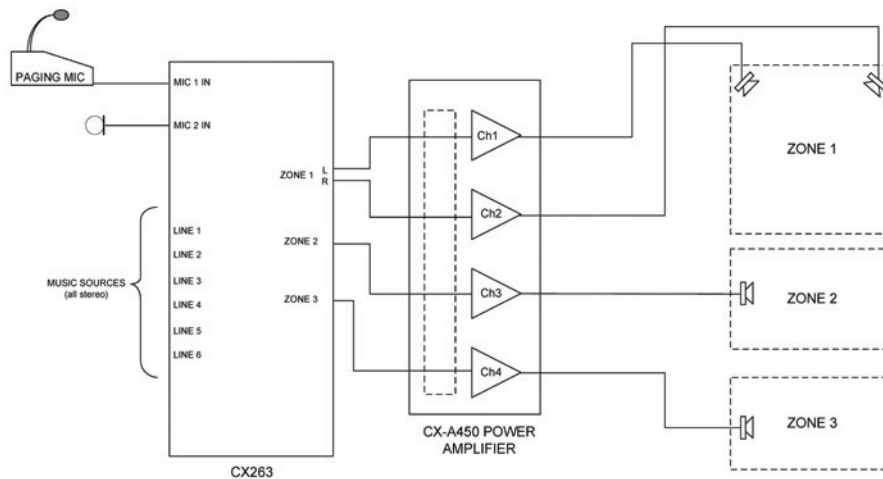

In another situation, it might be necessary to route the same audio to several different zones, but allow each zone to adjust its own level. This can be easily achieved by providing each zone with a Cloud RL-1 remote volume control plate, and setting the amplifier's input routing to parallel all the channels. Only a single input feed needs to be supplied, to Channel 1

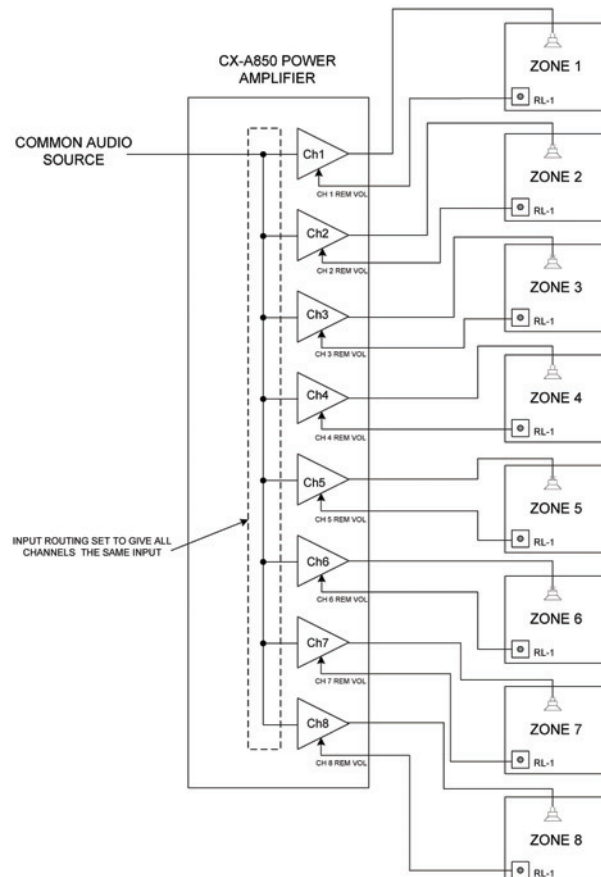

Graphs

Audio Precision CXA450 Frequency Response 05/31/11 15:06:04

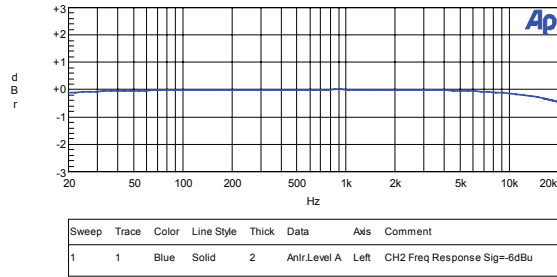

Audio Precision CX-A450 Crosstalk 05/31/11 12:21:05

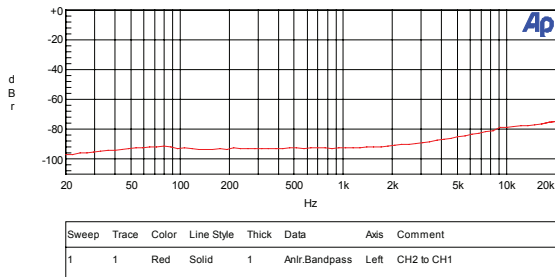

Audio Precision CX-A450 THD+N 05/31/11 13:11:59

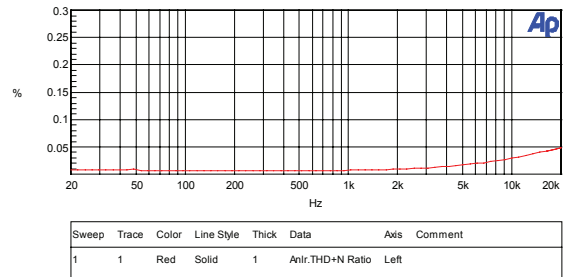

Audio Precision CX-A850 Frequency Response 05/31/11 11:22:06

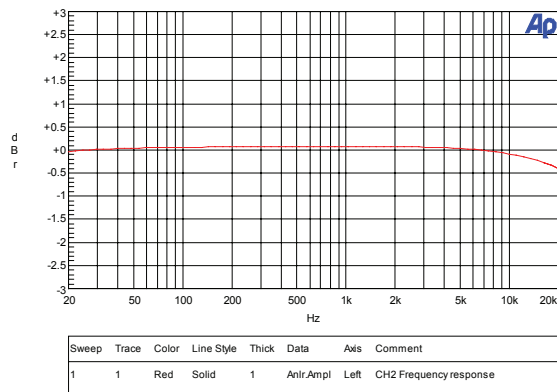

Audio Precision CX-A850 Crosstalk 05/31/11 13:23:50

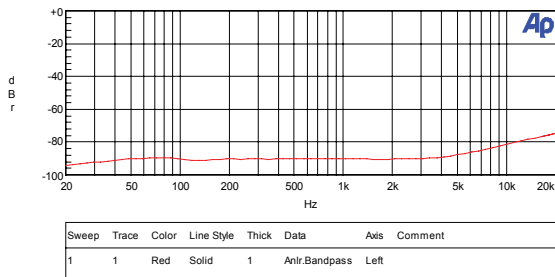

Audio Precision CX-A850 THD+N 05/31/11 13:27:47

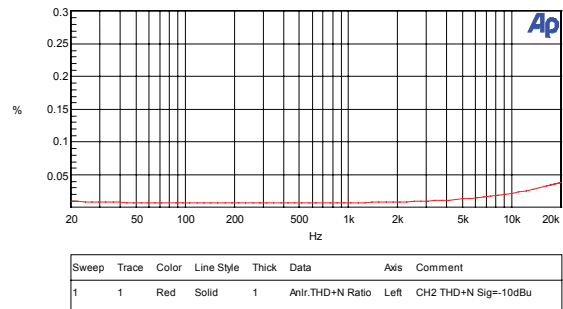

Technical Specifications

		CX-A450	CX-A850
Performance	Output Power (Normal Mode):	50 W/ch into 4 ohms (all chs driven)	50 W/ch into 4 ohms (nominal, continuous sinewave)
	Output Power (Bridge Mode):	100 W nominal into 8 ohms	
	Frequency Response:	10 Hz – 20 kHz, +0/-0.5 dB	
	High Pass Filter:	-3 dB @ 65 Hz, switchable per-channel	
	Distortion:	THD+N: <0.02% typical, 1 kHz, 60 W into 4 ohms, one channel driven, 22 Hz – 22 kHz	THD+N: <0.007% typical, 1 kHz, 60 W into 4 ohms, one channel driven, 22 Hz – 22 kHz
	Noise:	<-96 dB rel. rated output, unweighted, 22 Hz – 22 kHz	
	Crosstalk:	<-70 dB, rel. rated output into 4 ohms, 10 kHz	<-82 dB, rel. rated output into 4 ohms, 10 kHz
	VCA module THD+N:	<0.03%, 1 kHz, 22 Hz – 80 kHz BW	
Inputs	Type & connectors	Electronically balanced, 3-pin 3.5 mm-pitch screw-terminal connectors	
	Sensitivity	0 dBu (0.775 Vrms)	
	Input Impedance	10 kohms (balanced)	
General	Output Connectors (lo-Z)	2-pin 5 mm-pitch screw-terminal connectors	
	Output Connectors (100/70 V)	Screw terminals	
	Power input	230 V ±5% (115 V ±5% available)	
	Mains protection	Replaceable fuse, T3.15A H	Replaceable fuse, T4A H
	Amplifier Protection	VI limiting, DC offset, Thermal, Switch-on Delay & Dynamic Clipping Protection	
	Status Indicators	Signal present, Peak & Protection	
	Cooling	Force cooled, variable speed DC fan	
	Dimensions (W x H x D)	482.6 x 88 (2U) x 300 mm	
	Weight	7.15 kg	8.8 kg

Architect's and Engineer's Specification

The power amplifier shall have six identical channels. Each channel shall be capable of driving 120W into a 4 ohm load when all channels are driven simultaneously.

The amplifier's front panel shall incorporate an AC power switch, an LED indicating POWER ON, and LEDs indicating Signal Present, Peak Level and Protect status for each channel. The Signal Present LEDs shall illuminate when the input signal exceeds -22 dBu when the input sensitivity is set to maximum. The Peak LEDs shall illuminate when the output signal level is 0.5 dB below full output power. The Protect LEDs shall indicate activation of the channel protection circuitry.

The amplifier shall be provided with one input per channel and be able to operate in the following configurations as a minimum: all channels independent, one input feeding all channels or two inputs feeding the amplifier channels in pairs for stereo operation. Input sensitivity will be provided for each channel via a rear panel control permitting a range of operation from not less than 90 dB attenuation (min.) to unity gain (max.). The inputs shall be electronically balanced and capable of operating with both balanced and unbalanced sources. The input impedance shall be not less than 10 kohms in balanced mode. The input connectors shall be 3-pin XLR female type. It shall be possible to enable a high-pass 3rd order filter with a turnover frequency of 65 Hz independently in each amplifier channel.

Each channel shall deliver its rated power from an input signal of 0 dBu with input sensitivity controls set at maximum. Output mute protection on power-up and thermal protection shall be provided. The amplifier will also be protected against short-circuits at the

output, and excessive combination of output voltage and current. The amplifier's outputs shall be on 2-pin 5 mm-pitch screw-terminal connectors.

A range of optional, single-channel transformer modules, and suitable rackmounting housings, shall be available to permit the amplifier to drive 100V-line and 70V-line loudspeaker systems.

An optional control panel shall be available for any or all amplifier channels, to allow remote adjustment of channel gain. The variable gain element shall be an optional internally-fitted module, able to control the gain of two channels. The remote control connector shall be of Euroblock type. It shall be possible to link pairs of channels to enable one remote control panel to control two channels. It shall also be possible to fit optional EQ cards to any or all channels to suit a range of current, popular loudspeakers types.

The amplifier shall be built in a steel chassis suitable for mounting in a standard 19" equipment rack, and occupy two rack spaces. Two speedforced-air cooling shall be employed.

The amplifier shall be available in versions operating on either 230V or 115V AC mains, the intended mains voltage to be specified by the user at the time of order.

The power amplifier shall be the Cloud CX-A6; the remote level control panel the Cloud RL-1, and the 2-channel gain control module the Cloud VCA-2.