

EXAMPLE N°17

STANDING VIDEO FLOOR MOUNT
9 DISPLAYS (VIDEOWALL 3x3)

VESA 200x200 TO 600x400
50 KG / DISPLAY



ALUMINUM /
BLACK COLOR

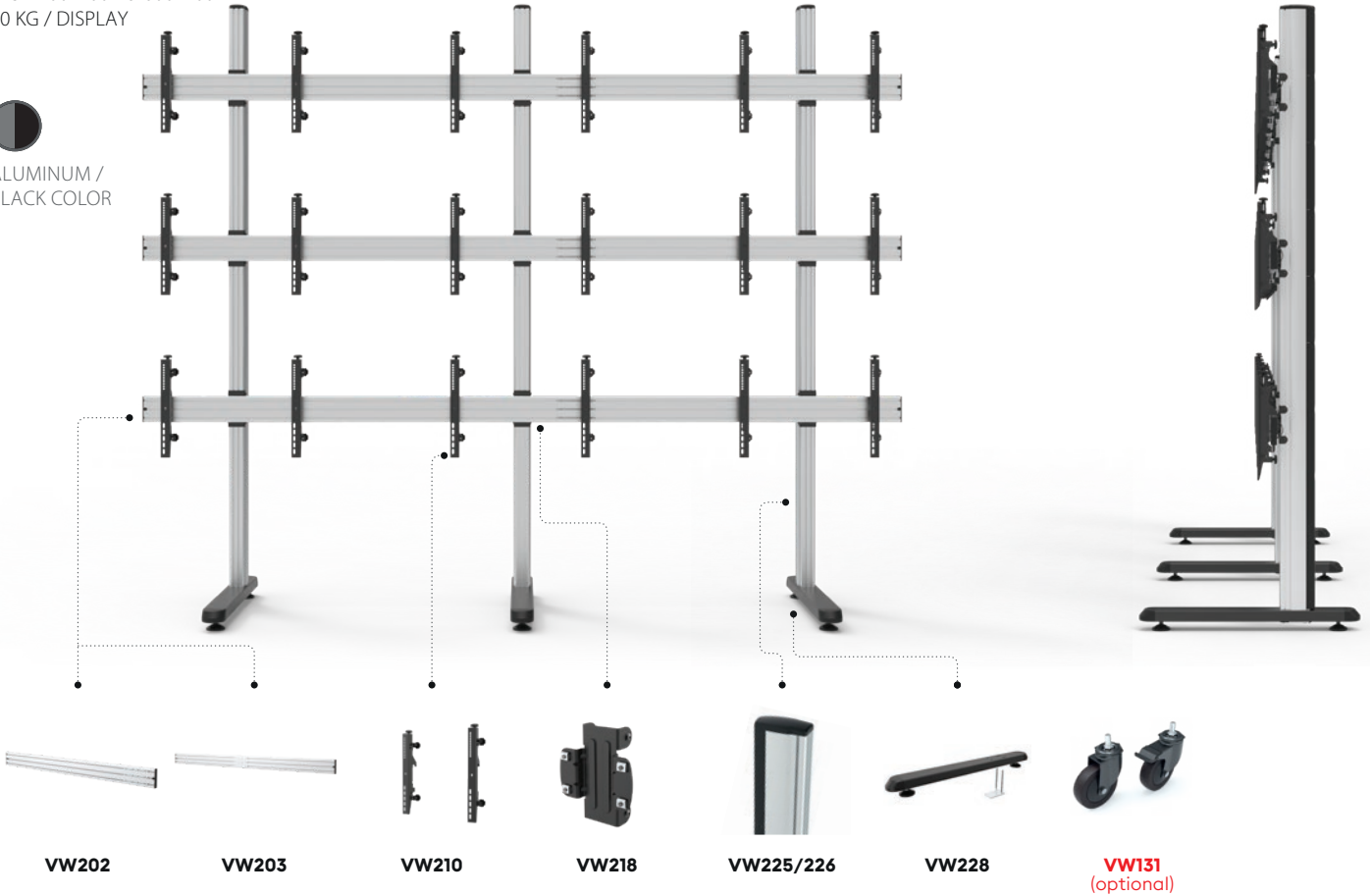

PARTS & COMPONENTS



REF	EAN	DESIGNATION	QTY	CATALOG
VW202	5603209022023	ALUMINUM RAIL 1500MM	3	Pag.21
VW203	5603209022030	ALUMINUM RAIL 2000MM	3	Pag.21
VW210	5603209022108	MICRO-ADJUSTABLE ARM 400MM	9	Pag.21
VW218	5603209022184	RAIL / COLUMN CONNECTOR	9	Pag.21
VW226	5603209022269	ALUMINIUM COLUMN 2700MM	3	Pag.22
VW228	5603209022283	LEG 1000MM	3	Pag.22
VW131	5603209091319	4" WHEELS [2PCS/SET]	3	Pag.21

ALL DIMENSION (MM)

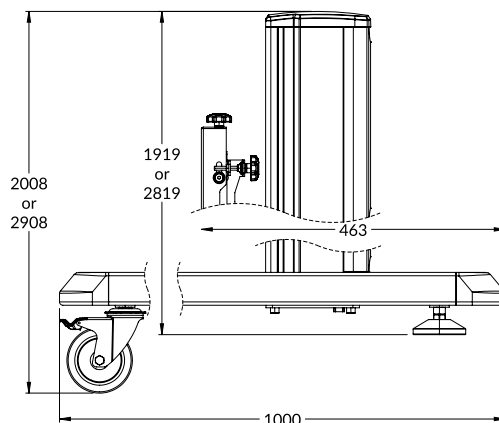

EASY TO INSTALL
AND COMBINE

FREEDOM TO CREATE
MODULAR MOUNT
WITH **UNLIMITED**
CONFIGURATION