

EXAMPLE N°27

GROUND BOLTED VIDEO FLOOR MOUNT
3 DISPLAYS (TILT MENUBOARD 3x1)

VESA 200x200 TO 600x400
TILT -20° / 0°
50 KG / DISPLAY

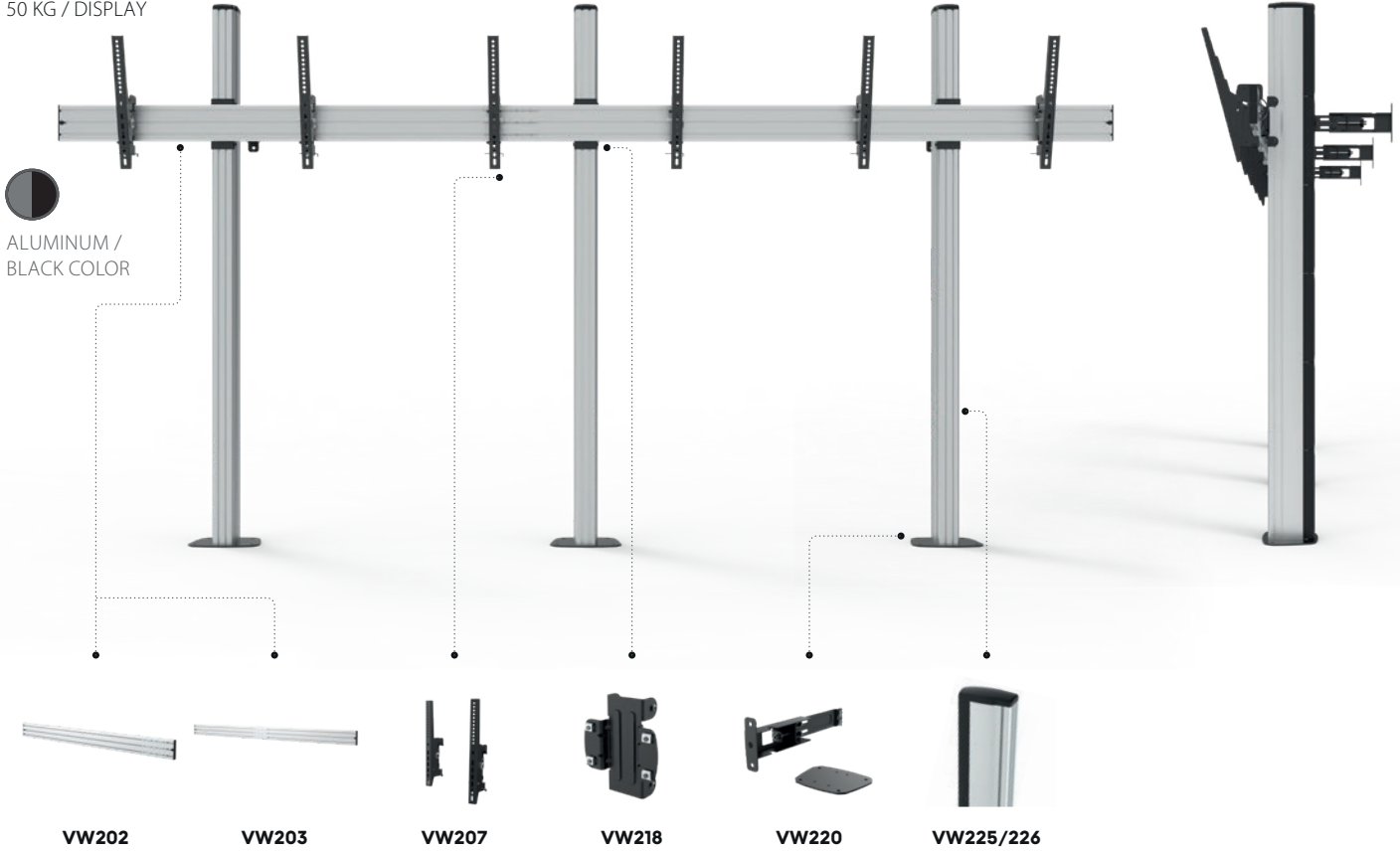

PARTS & COMPONENTS



REF	EAN	DESIGNATION	QTY	CATALOG
VW202	5603209022023	ALUMINUM RAIL 1500MM	1	Pag.21
VW203	5603209022030	ALUMINUM RAIL 2000MM	1	Pag.21
VW207	5603209022078	TILT ARM 400MM	3	Pag.21
VW218	5603209022184	RAIL / COLUMN CONNECTOR	3	Pag.21
VW220	5603209022207	BASE PLATE + WALL SAFETY BRACKET	3	Pag.21
VW225	5603209022252	ALUMINIUM COLUMN 1800MM	3	Pag.22

ALL DIMENSION (MM)

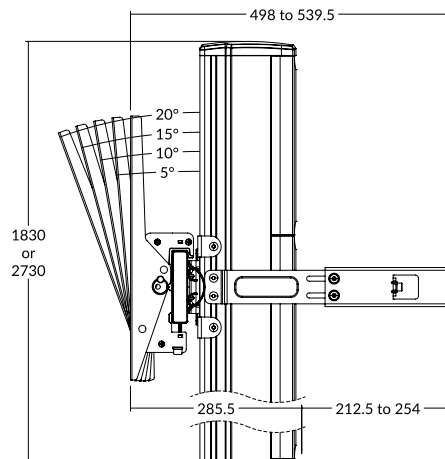

EASY TO INSTALL AND COMBINE

FREEDOM TO CREATE
MODULAR MOUNT WITH **UNLIMITED** CONFIGURATION