



The **CEILING TILE HOLDER** is an useful accessory suitable both for projector lifts of the SI and SI-H L series. This accessory helps installers to reach a perfect aesthetic result when the projector lift is hidden inside the false ceiling.

The packaging includes the aluminium frame and the brackets for fixing the threaded rods, which are included with the projector lift.

After the tile holder is mounted, the installer has to fit in the frame a tile (not supplied).

- Width of the aluminium frame seen from the bottom side: 30 mm.
- Packaging includes: aluminium frame divided in 4 pieces, 2 brackets for fixing the threaded rods, bolts and nuts
- Packaging does NOT include: tile for the false ceiling and threaded rods
- **Aluminium frame is supplied RAW**, without any painting. The installer can spray it with a colour at his choice.

## CEILING TILE HOLDER CT-570

It is suitable with the following projector lift models:

- SI-30
- SI-100
- SI-200
- SI-H L 100
- SI-H L 200
- SI-H L 300

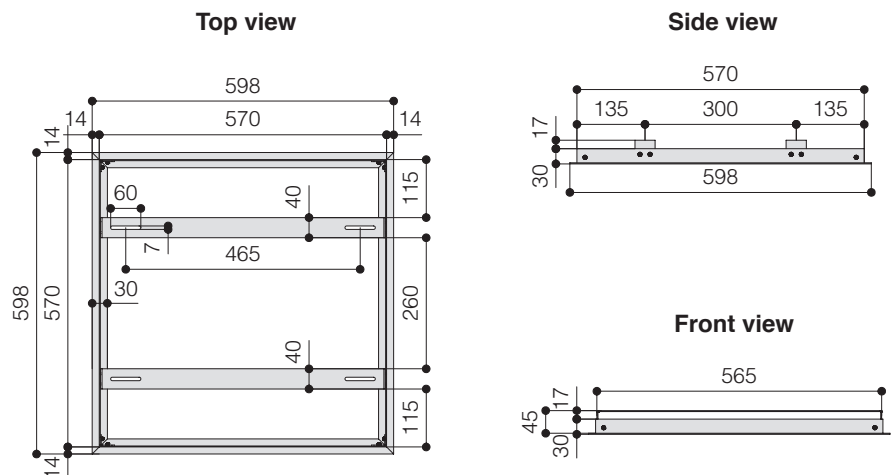

## CEILING TILE HOLDER CT-660

It is suitable with the following projector lift model:

- SI-H L 40 HC

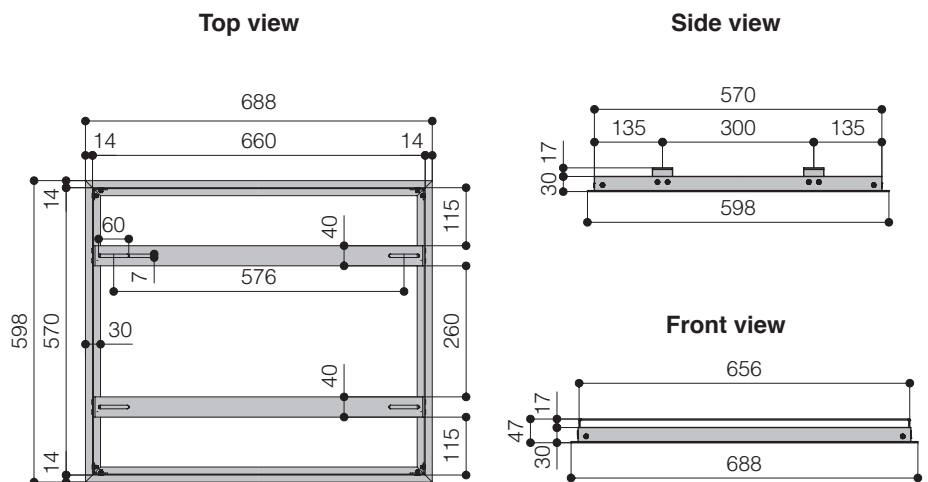

The measures in the drawings are expressed in millimetres.

**Warranty:** 24 months