



**DOUBLE FORMAT
HOME CINEMA**

**DOUBLE FORMAT
TENSIONED**

The brand new **DOUBLE FORMAT** developed by ScreenInt® has an innovative smart design housing which allows to reduce the needed space in the depth.

The philosophy of this product is to offer the possibility to have two projections screens in a single housing.

Due to this feature, it is possible to choose two different projections surfaces and each with a different video format, specifically for the required application.

The two available versions are:

- **Home Cinema** supplied with black side borders and black top drop of 30 cm. (customizable)
- **Tensioned** supplied with black tensioned side borders and black top drop of 30 cm. (customizable)

This screen can also be used to project on it simultaneously from the two opposite sides with two separate projectors, inside a room where spectators are watching the screen both from the front and from the rear side.

For this use, the second cloth will be reversed wound.

*Available in all video formats and **bespoke sizes**.*

**WALL MOUNTING
BRACKET**

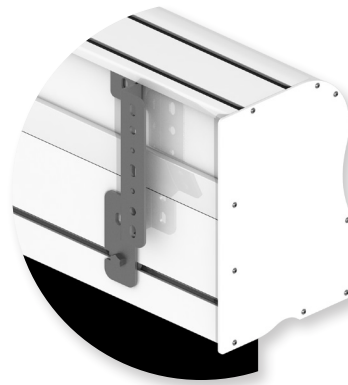

**CEILING MOUNTING
BRACKET**

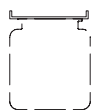

Ceiling mounting brackets

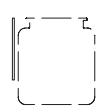

Wall mounting brackets



n.2 On/off switcher



Extremely quiet motor

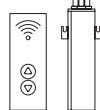

Kit RF Remote control with external receiver



Interface switch 12 volt



Low voltage contact interface



Interface RS485



Nm 9 Rpm 26

Faster motor

INCLUDED

OPTIONAL pag 70-71



WALL MOUNTING

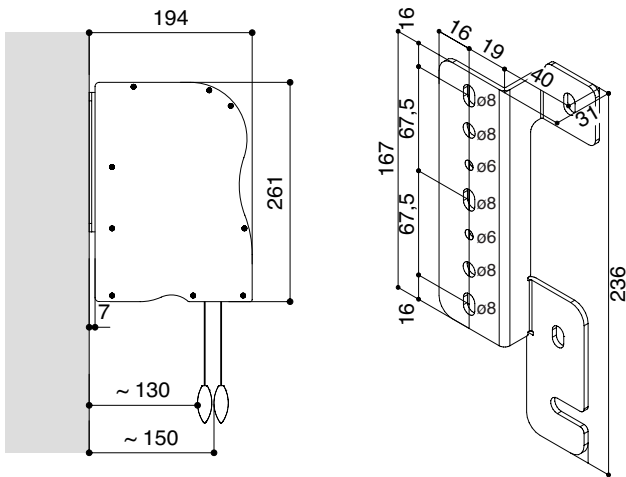

CEILING MOUNTING

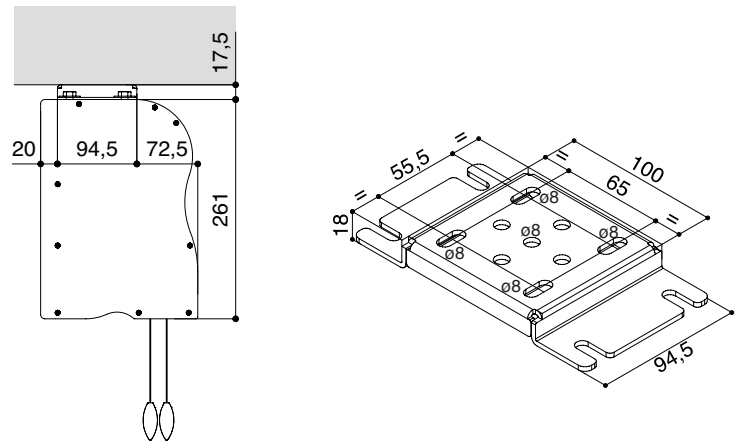

DOUBLE FORMAT HOME CINEMA

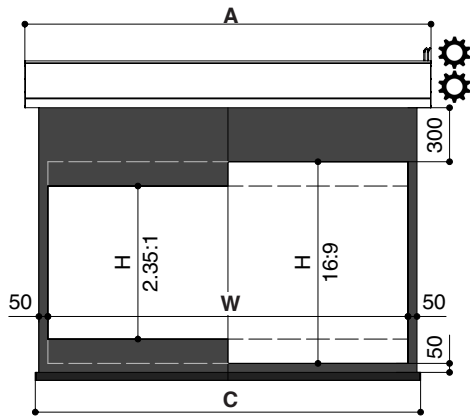

DOUBLE FORMAT TENSIONED

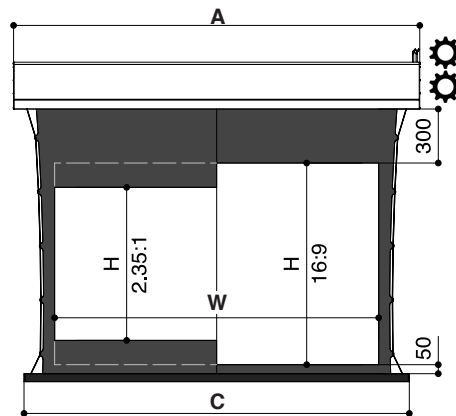

TECHNICAL SPECIFICATIONS

- Silent motor system provides a smooth and quiet operation
 - Power: **7 Nm**
 - Speed: **18 rpm**
 - Power supply: **230V / 50 Hz**
 - Consumption: **120 W**
 - Certification: **IMQ**
- Housing dimensions: 194x261 mm. (DxH)
- Housing painted with white epoxy powders (RAL 9010)
- Mounting brackets for ceiling and for wall included
- Two on/off switchers included
- Power cables located at the **right** side of the screen housing seen from the front.
- Flame-retardant projection surfaces
- **Home Cinema version:** black side borders of 5 cm., black top drop from 30 cm. on, black bottom border of 5 cm. and black dowel bar: height 44 mm.- depth 17 mm.
- **Tensioned version:** black tensioned side borders of 5 cm (in the narrowest point), black top drop from 30 cm. on, black bottom border of 5 cm. and black dowel bar: height 44 mm.- depth 17 mm.
- **Housing available in different colours (optional)**

The measures in the drawings are expressed in millimetres.

DIMENSIONS measures in cm

16:9 Ratio Viewing area (WxH)	2.35:1 Ratio Viewing area (WxH)	Overall dimensions A - C HOME CINEMA	Approx. net weight (Kg) HOME CINEMA	Overall dimensions A - C TENSIONED	Approx. net weight (Kg) TENSIONED
160 x 90	160 x 68	191 - 174	38	210 - 193	41
180 x 101	180 x 77	211 - 194	41	230 - 213	44
200 x 112	200 x 85	231 - 214	44	250 - 233	47
220 x 124	220 x 94	251 - 234	48	270 - 253	50
250 x 140	250 x 106	281 - 264	53	300 - 283	55
270 x 152	270 x 115	301 - 284	56	320 - 303	59
300 x 169	300 x 128	331 - 314	61	350 - 333	64
350 x 190	350 x 149	381 - 364	59	400 - 383	72
400 x 225	400 x 170	431 - 414	78	450 - 433	81

PROJECTION CLOTHS

DOUBLE FORMAT HOME CINEMA	Gain	DOUBLE FORMAT TENSIONED	Gain
Matte White	1.2	Matte White	1.2
Pure KS	1.1	Pure KS	1.1
Pure Matte KS	1.1	Pure Matte KS	1.1
Lumi Grey	0.8	Lumi Grey	0.8
Microperforated	1.1	Microperforated	1.1
Lumi Grey Microperforated	0.8	Lumi Grey Microperforated	0.8
Cinesound*	0.7	Cinesound*	0.7
Bright Contrast 3D 0.8*	0.8	Bright Contrast 3D 0.8*	0.8
Fibre Matte*	1.25	Silver Blast*	1.3

*Limited in height

Warranty: 5 years on the motor - 24 months on the other components

