



RAFFAELLO HOME CINEMA is a new electric projection screen, that has an innovative mechanical construction which makes it an ideal and unique solution for in-ceiling installations both in residential and AV professional environments.

Its peculiarity is that, once mounted inside the false ceiling, **the product is completely hidden and no visible openings can be seen.**

The mechanism is composed by two silent and fast motors, one for the opening of the trap door and the other for rolling down of the projection screen.

This model has black side borders of 5 cm. of width and a black top drop of 30 cm.

IMPORTANT: The structure allows substitution of the projection surface rolling pipe without the need to uninstall the product completely.

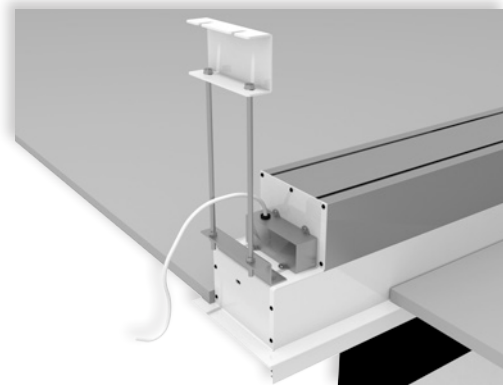

LEFT SIDE VIEW (motor side)

Available in 4:3, 16:9 and 16:10 formats or bespoke sizes.



n.2
Ceiling
mounting
brackets



n.1
On/off
switcher

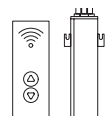

Kit RF Remote
control with
external
receiver



Interface
switch 12 volt



Low voltage
contact
interface

INCLUDED

OPTIONAL pag 62-63

CEILING BRACKET

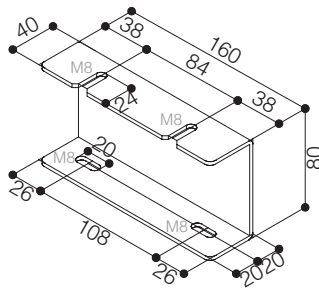

DIMENSIONS OF THE HOLE TO BE MADE IN THE FALSE CEILING

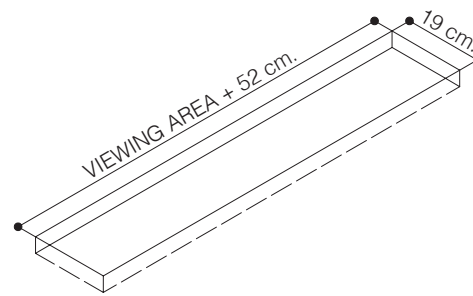

HOUSING SIDE VIEW

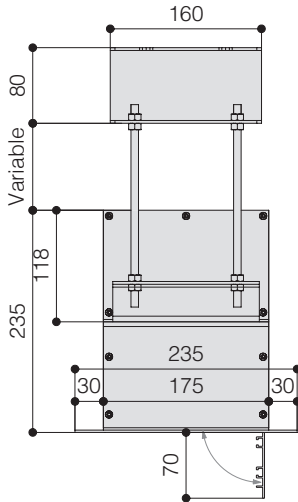

HOUSING FRONT VIEW

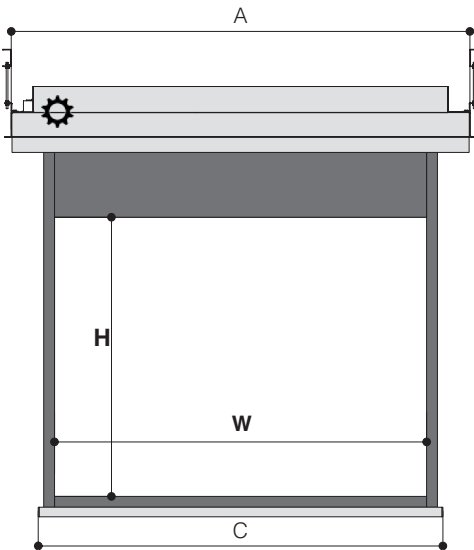
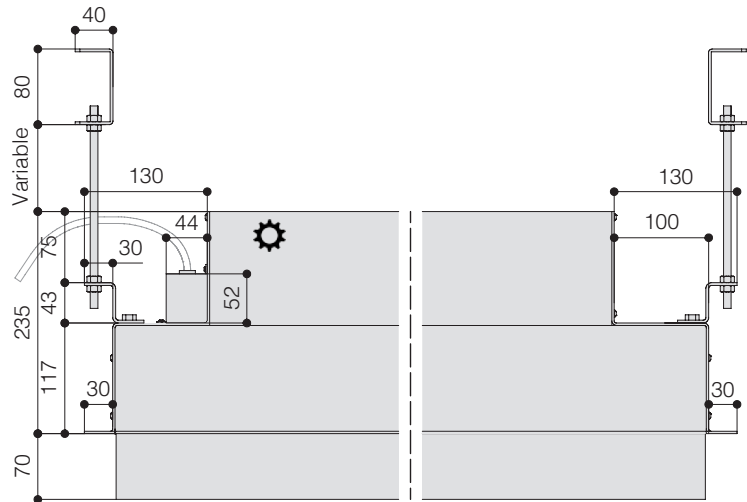

TECHNICAL SPECIFICATIONS

- Silent motor system provides a smooth and quiet operation
 - Power: **9 Nm**
 - Speed: **26 rpm**
 - Power supply: **230V / 50 Hz**
 - Consumption: **184 W**
 - Certification: **IMQ**
- Housing manufactured from aluminium
- Lower part of the housing, trap door and bezel sprayed with white epoxy powders (RAL 9010)
- Black dowel bar: height 44 mm. - depth 17 mm.
- Two ceiling mounting brackets with four threaded rods 100 cm. long
- On/Off switcher included
- Screen standard supplied with **cloth dropping** down from the front side of the housing
- Flame - retardant projection surfaces - classification M1, M2 and B1
- Side black borders of 5 cm. width, black bottom border of 5 cm. and black top drop of 30 cm.
- Minimum height needed into the false ceiling: 25 cm.
- Screen housing available in different colours (*optional*)

The measures in the drawings are expressed in millimetres.

DIMENSIONS measures in cm

4:3 Ratio Viewing area (WxH)	16:9 Ratio Viewing area (WxH)	16:10 Ratio Viewing area (WxH)	Overall dimensions A - C	Approx. net weight (Kg)
160 x 120	160 x 90	160 x 100	211 - 174	39
180 x 135	180 x 101	180 x 112	231 - 194	41
200 x 150	200 x 112	200 x 125	251 - 214	44
220 x 165	220 x 124	220 x 137	271 - 234	47
250 x 190	250 x 140	250 x 156	301 - 264	52
300 x 225	300 x 169	300 x 187	351 - 314	59
350 x 265	350 x 197	350 x 219	401 - 364	66
400 x 300	400 x 225	400 x 250	451 - 414	73

PROJECTION CLOTHS

Front projection surfaces	Gain	
White	1.2	
Matte White	1.0	
Lumi Grey	0.8	
Cinesound*	0.7	
Microperforated	1.1	
Lumi Grey Microperforated	0.8	
Fibre Matte*	1.25	
Ultra HD	1.2	

*Limited in height

Warranty: 5 years on the motor - 24 months on the other components

